

NUMBER
C-1775841

3RD ANGLE PROJECTION

METRIC

THIS INFORMATION IS CONFIDENTIAL AND IS DISCLOSED TO YOU ON CONDITION THAT NO FURTHER DISCLOSURE IS MADE BY YOU TO OTHER THAN AMP PERSONNEL WITHOUT WRITTEN AUTHORIZATION FROM AMP (TAIWAN) LTD.

PRINT DIST DW

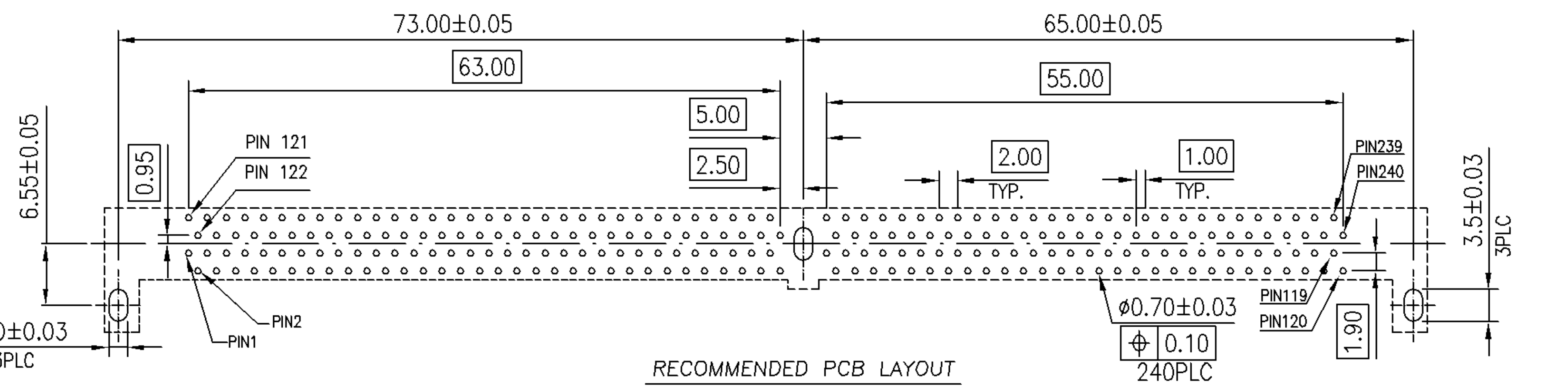
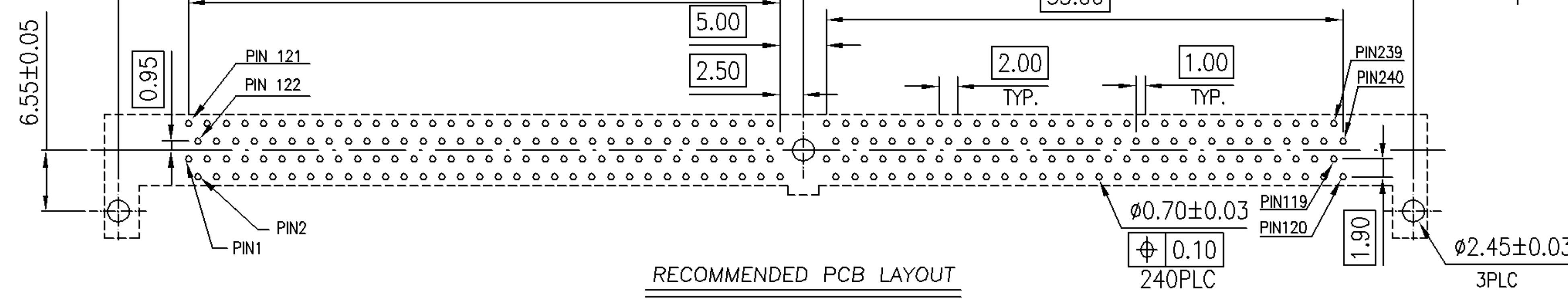
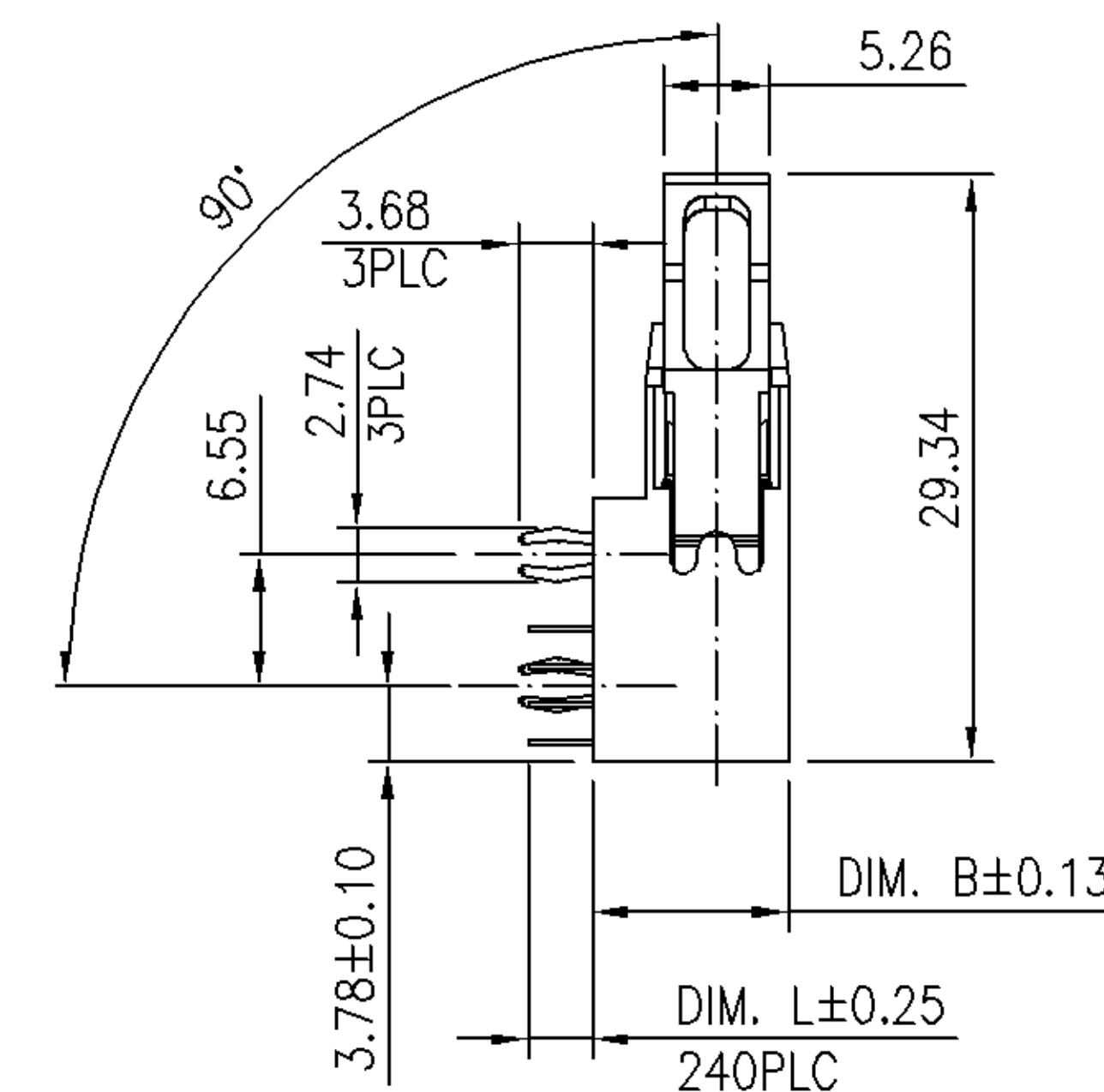
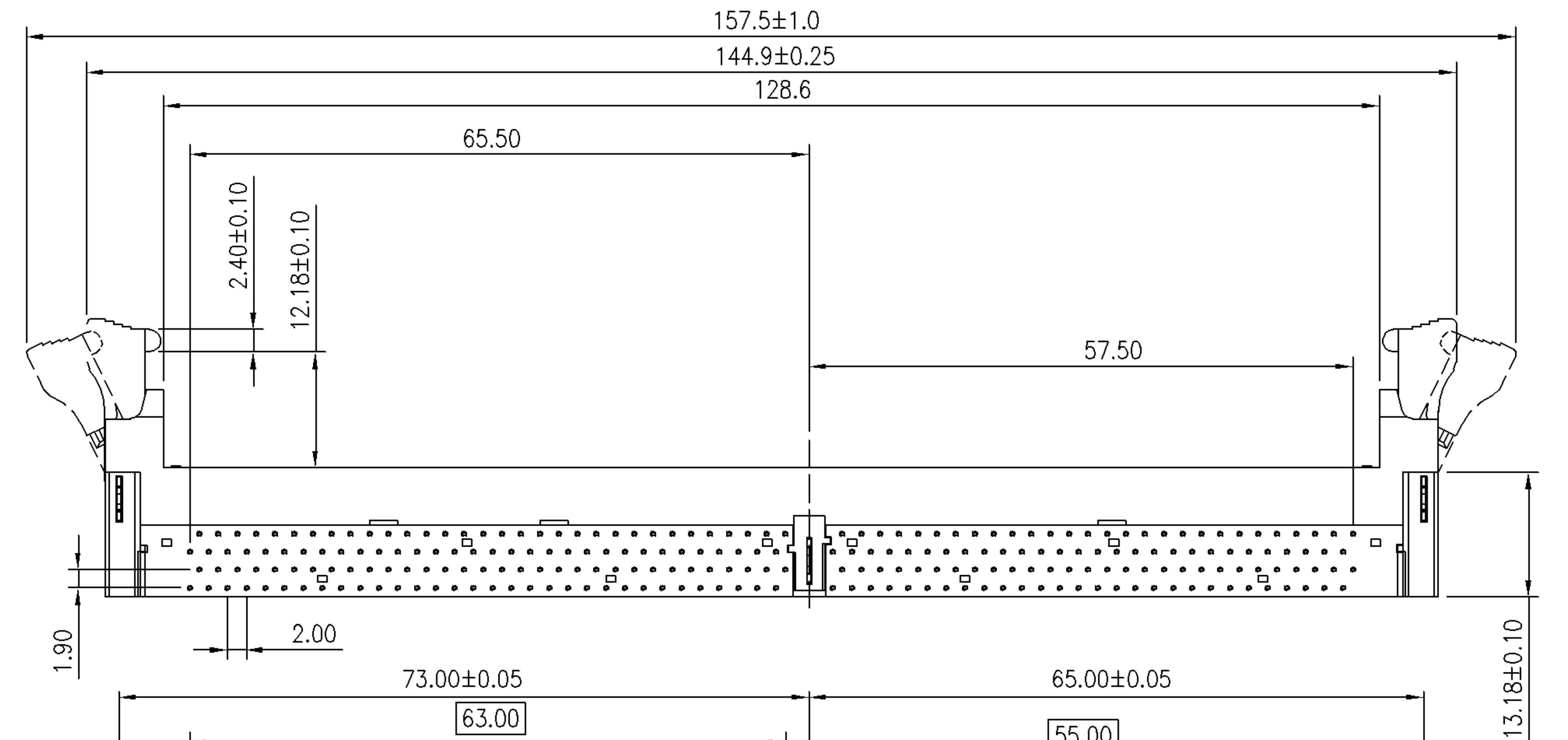
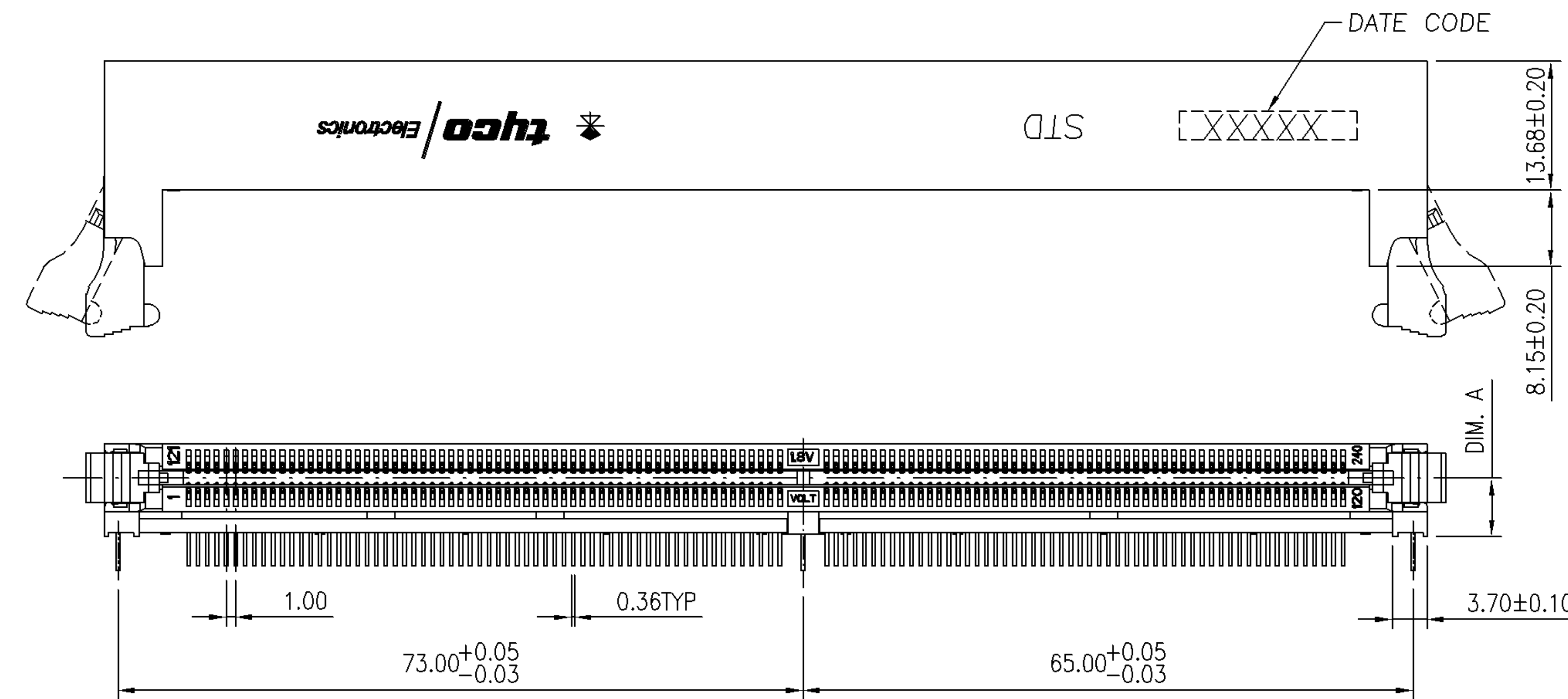

NOTES:

- MATERIAL:
 - HOUSING: THERMOPLASTIC, (PA46), UL94V-0; COLOR:BLACK.
 - EXTRACTOR: THERMOPLASTIC, (PA46), UL94V-0; COLOR:WHITE.
 - CONTACTS: PHOSPHOR BRONZE
 - BOARDLOCK: BRASS
- FINISH:
 - CONTACT: GOLD PLATING(SEE TABLE) ON CONTACT AREA, 3.75μm[100μ"] MIN. MATTE TIN PLATING ON SOLDER TAILS, 1.25μm[50μ"] MIN. NICKEL UNDERPLATING OVERALL.
 - BOARDLOCK: 2.5μm[100μ"] MIN. MATTE TIN PLATING ON SOLDER TAIL AREA, 1.25μm[50μ"] MIN. NICKEL UNDERPLATING OVERALL,
- RECOMMENDED PCB THICKNESS : 1.2~1.8mm
- WAVE SOLDER CAPABLE TO 265°C PER TYCO SPEC. 109-202, CONDITION B.
- NET WEIGHT : DIM. B=9.8mm: 9.13gram
DIM. B=12.3mm: 9.65gram.

DIM. B	DIM. A	MIN. GOLD PLATING	DIM. L	PART NUMBER	
12.30	8.70	0.75μm [30μ"]	3.60	2-	-8
			3.18	2-	-7
			2.54	2-	-6
		0.375μm [15μ"]	2.00	2-	-5
			3.60	1-	-8
			3.18	1-	-7
9.80	6.20	0.75μm [30μ"]	2.54	1-	-6
			2.00	1-	-5
			3.60		-8
		0.375μm [15μ"]	3.18		-7
			2.54		-6
			2.00		-5
0.05μm [2μ"]		3.60		-8	
		3.18		-7	
		2.54		-6	
0.75μm [30μ"]		2.00		-5	
		3.60	2-	-4	
		3.18	2-	-3	
0.375μm [15μ"]		2.54	2-	-2	
		2.00	2-	-1	
		3.60	1-	-4	
0.05μm [2μ"]		3.18	1-	-3	
		2.54	1-	-2	
		2.00	1-	-1	
				1775841-1	

STANDARD TYPE

A	FIRST RELEASED	--	SH	17MAR 2006
LTR	REVISION RECORD	ECN	DWN	CHK

TOLERANCES UNLESS OTHERWISE SPECIFIED: 0 PLC ± 1 PLC ±0.3 2 PLC ±0.2 3 PLC ± ANGLES ±3'	DWN S. HOU 17-MAR-2006	tyco TYCO HOLDINGS (BERMUDA) VII LTD. TAIWAN BRANCH
MATERIAL SEE NOTE	CHK W.J. KE 17-MAR-2006	
FINISH SEE NOTE	APVD W.J. KE 17-MAR-2006	NAME DDR DIMM SOCKET 240P, R/A, DIP CONNECTOR
	PRODUCT SPEC 108-57376	
	QUALIFICATION TEST REPORT 501-57815	LOC DW SIZE A₃ DRAWING NO C-1775841 REV A
	WEIGHT SEE NOTE	SCALE -- SHEET 1 OF 6

NUMBER
C-1775841

3RD ANGLE PROJECTION

METRIC

THIS INFORMATION IS CONFIDENTIAL AND IS DISCLOSED TO YOU ON CONDITION THAT NO FURTHER DISCLOSURE IS MADE BY YOU TO OTHER THAN AMP PERSONNEL WITHOUT WRITTEN AUTHORIZATION FROM AMP (TAIWAN) LTD. DIMENSIONS IN MILLIMETERS. DO NOT SCALE PRINT.

PRINT DIST
DW

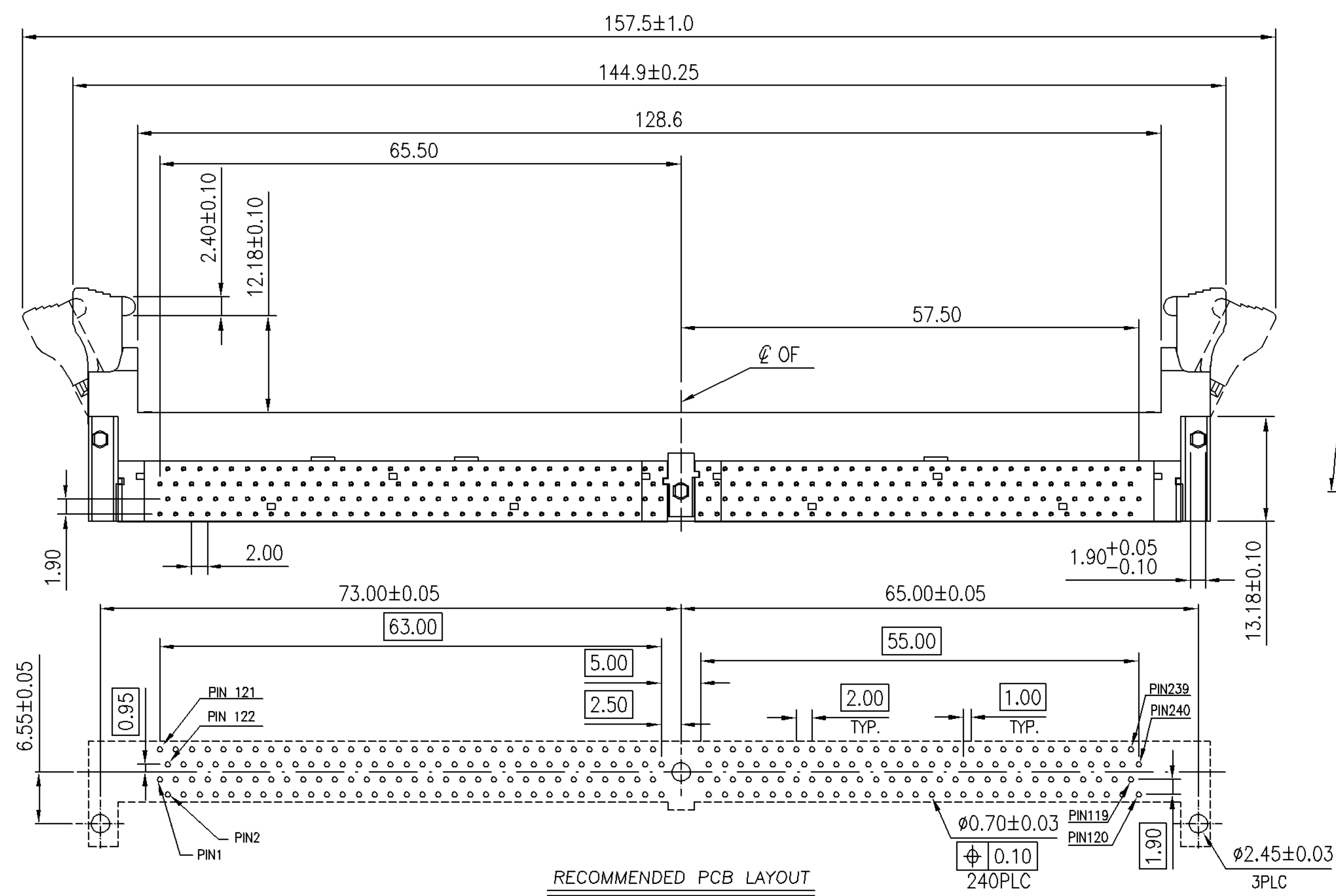
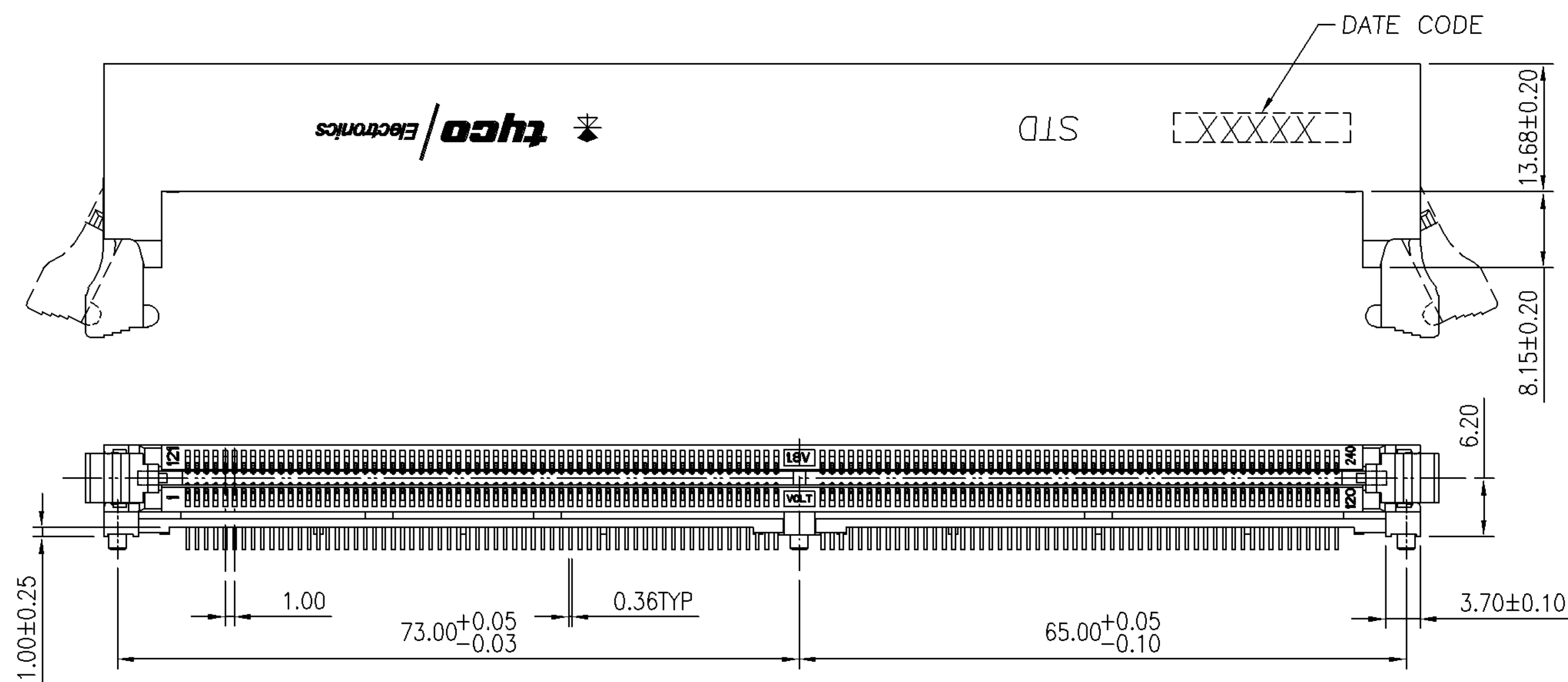

RECOMMENDED PCB LAYOUT

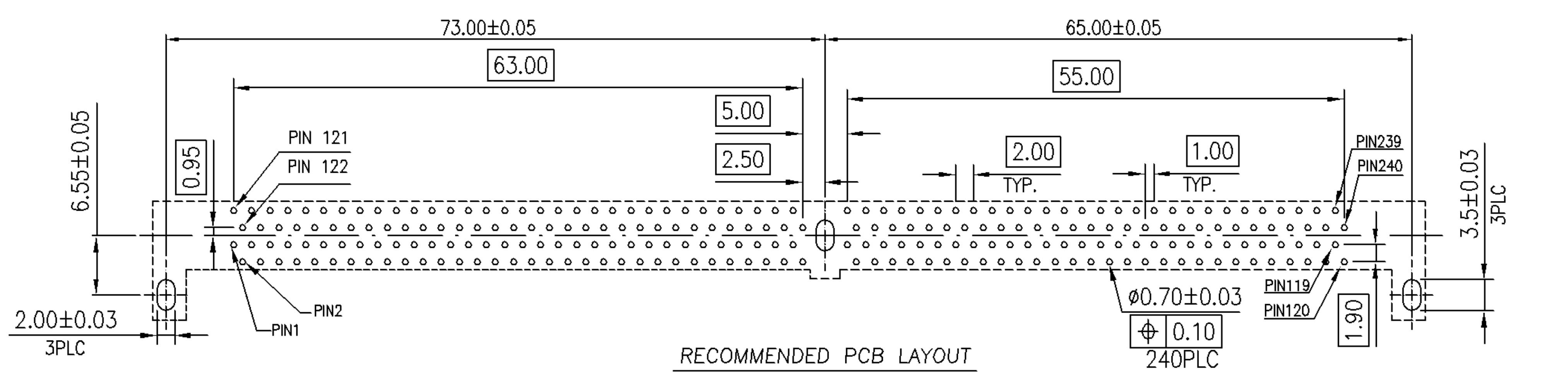

RECOMMENDED PCB LAYOUT

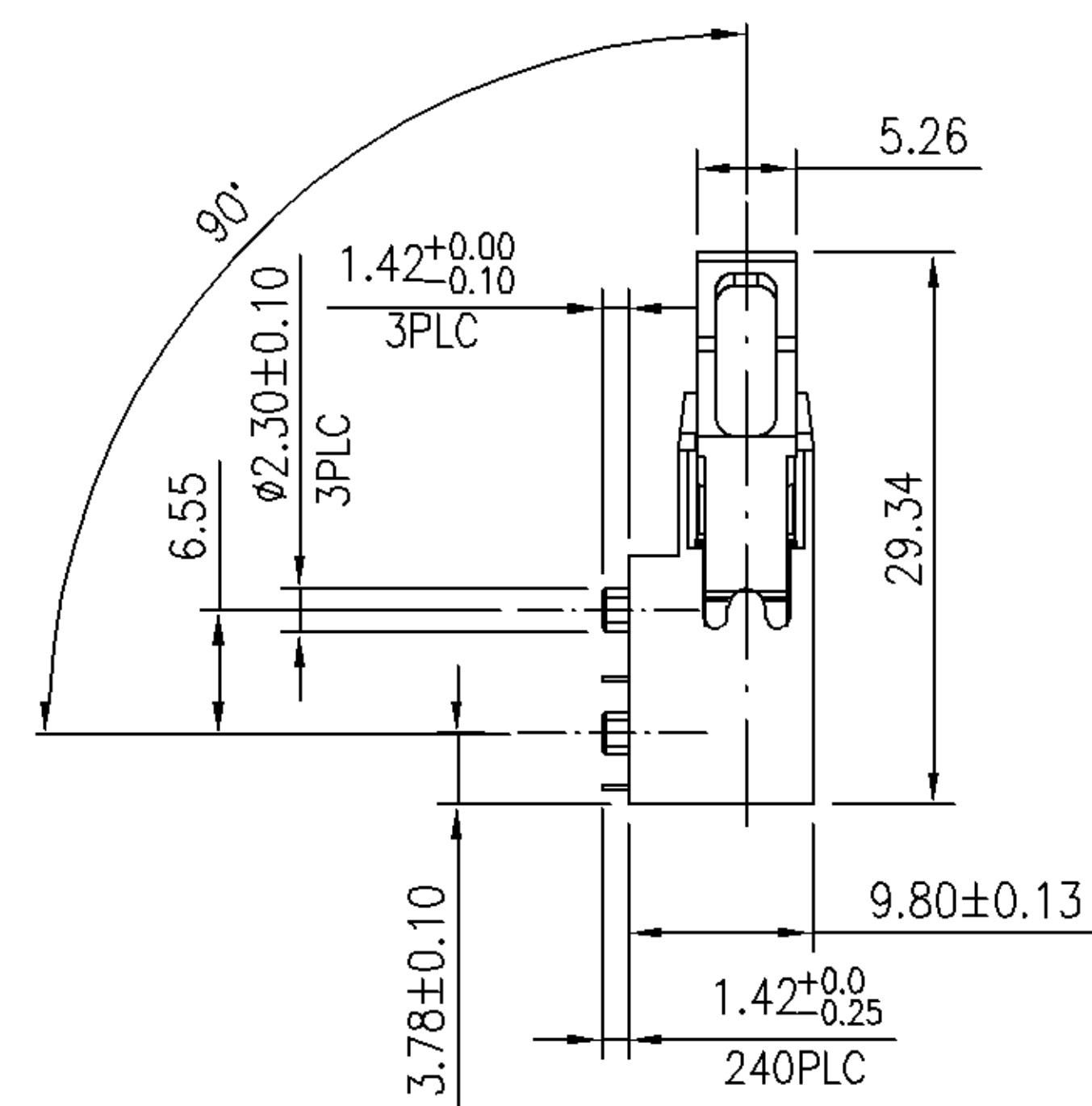

STANDARD TYPE

LTR	SEE SHEET 1	ECN	DWN	DATE
	REVISION RECORD		CHK	

TOLERANCES UNLESS OTHERWISE SPECIFIED: 0 PLC ± 1 PLC ±0.3 2 PLC ±0.2 3 PLC ± ANGLES ±3'	DWN S. HOU 17-MAR-2006 CHK W.J. KE 17-MAR-2006
MATERIAL SEE NOTE	APVD W.J. KE 17-MAR-2006
FINISH SEE NOTE	QUALIFICATION TEST REPORT WEIGHT 9.13 GRAM

LOC DW	SIZE A ₃	DRAWING NO C-1775841	REV A
SCALE --		SHEET 2 OF 6	

30µ" MIN. 2-1775841-9		GOLD PLATING		PART NUMBER	
tyco TYCO HOLDINGS (BERMUDA) VII LTD. TAIWAN BRANCH Electronics NAME DDR DIMM SOCKET 240P, R/A, DIP CONNECTOR					

CUSTOMER DRAWING

D
C
B
A

NUMBER
C-1775841

3RD ANGLE PROJECTION

METRIC

THIS INFORMATION IS CONFIDENTIAL AND IS DISCLOSED TO YOU ON CONDITION THAT NO FURTHER DISCLOSURE IS MADE BY YOU TO OTHER THAN AMP PERSONNEL WITHOUT WRITTEN AUTHORIZATION FROM AMP (TAIWAN) LTD. DIMENSIONS IN MILLIMETERS. DO NOT SCALE PRINT.

PRINT DIST
DW

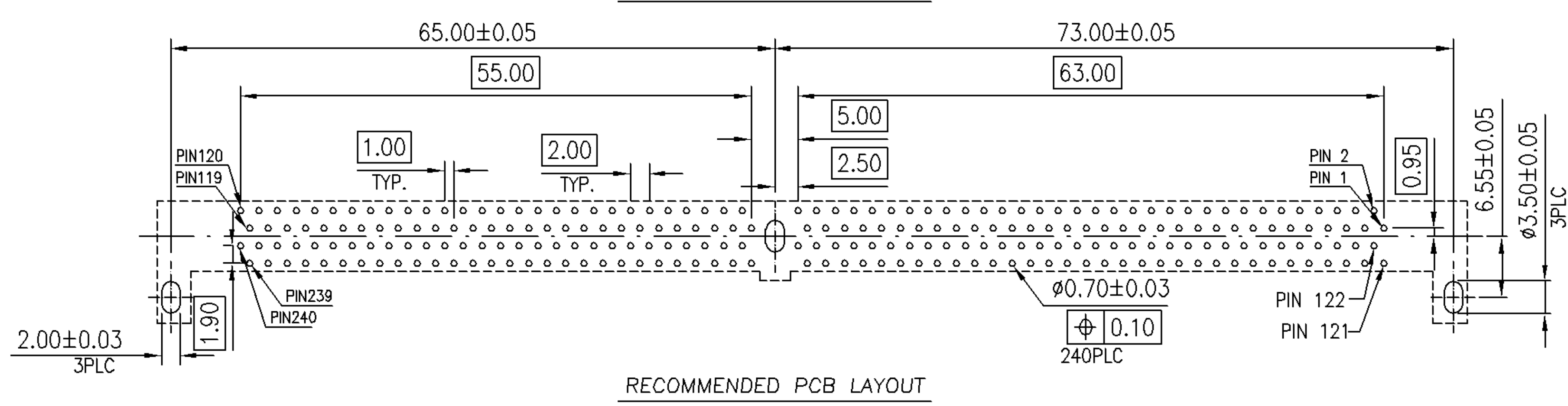
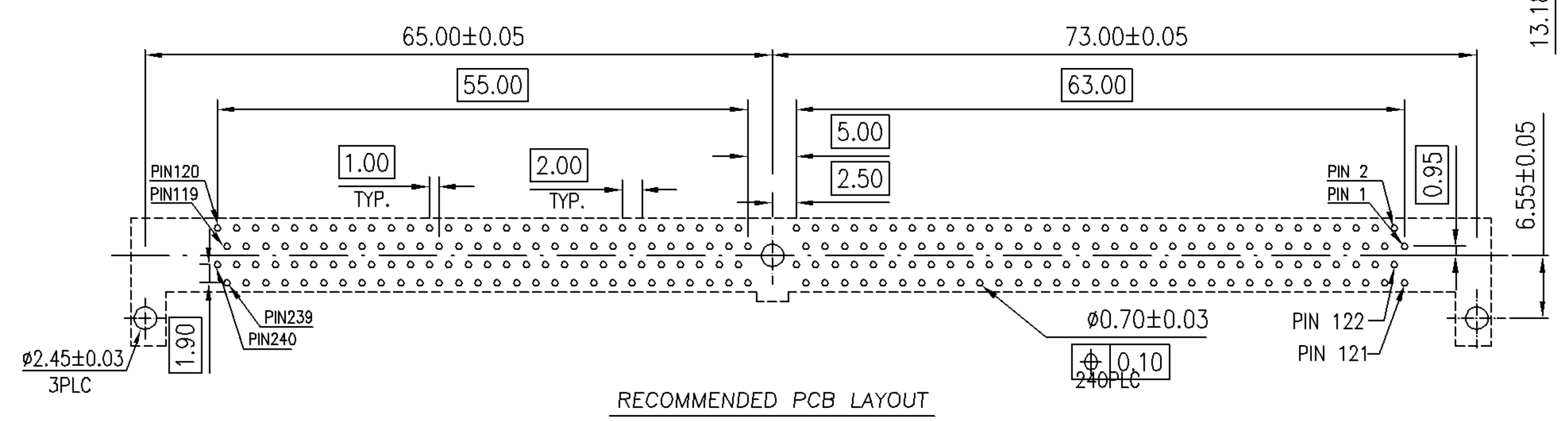
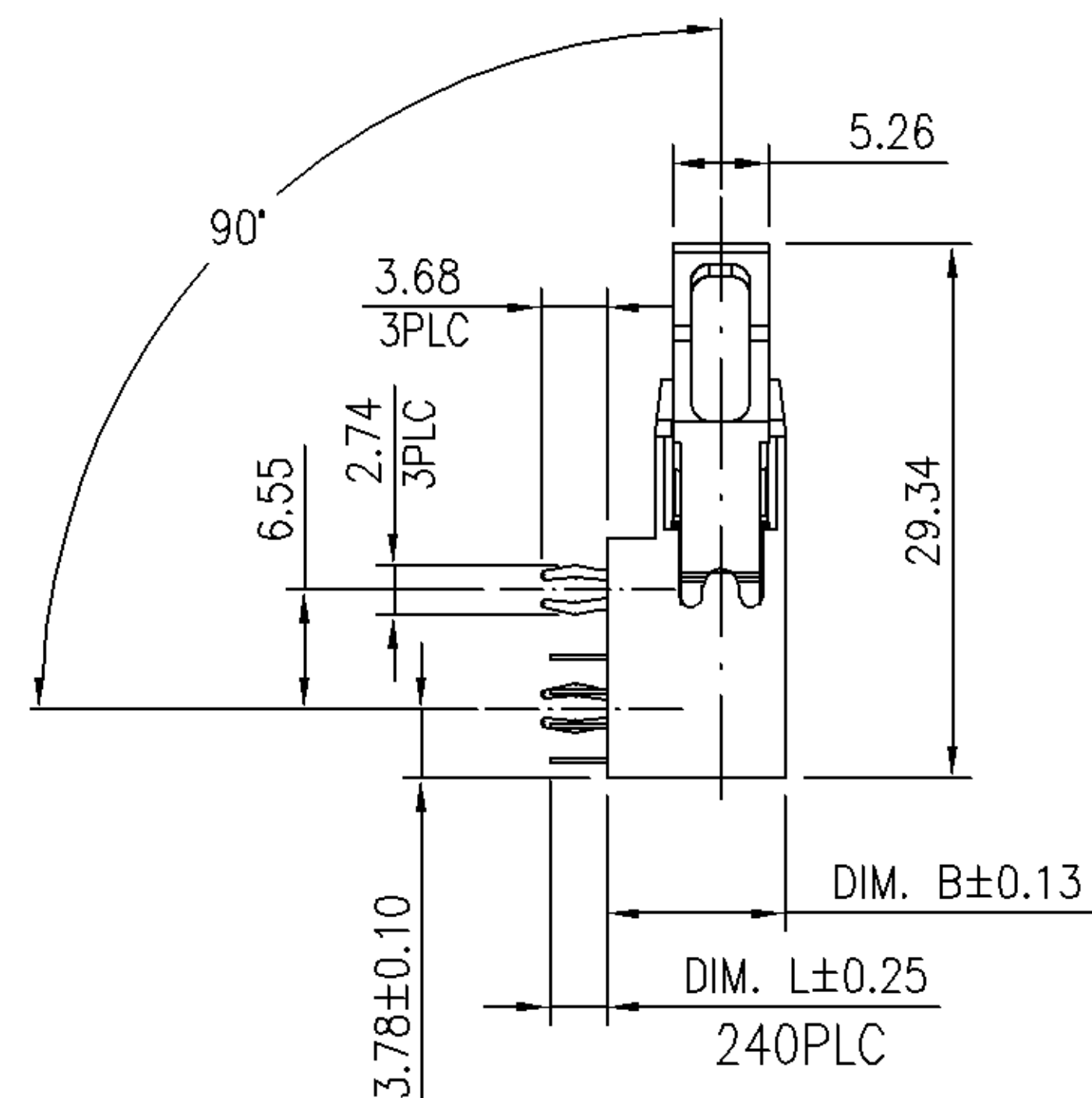
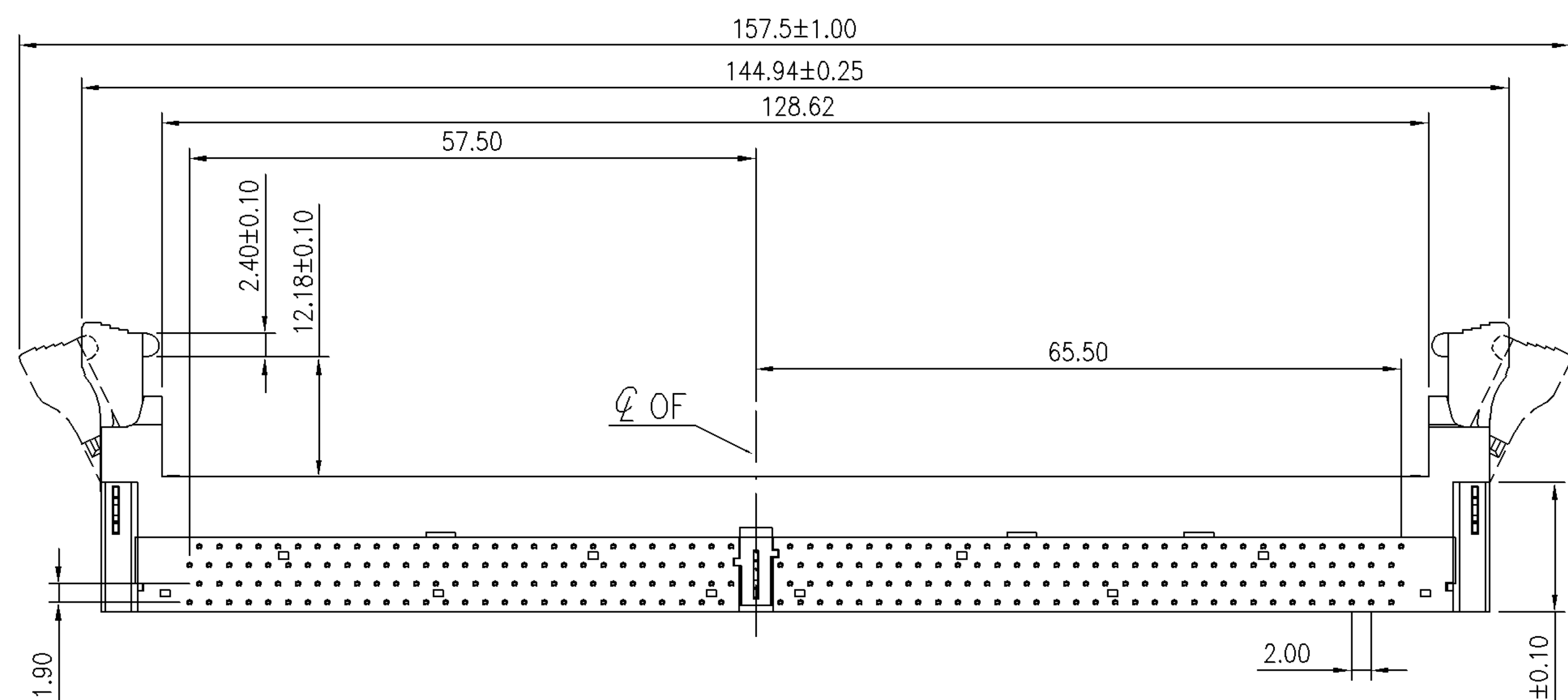
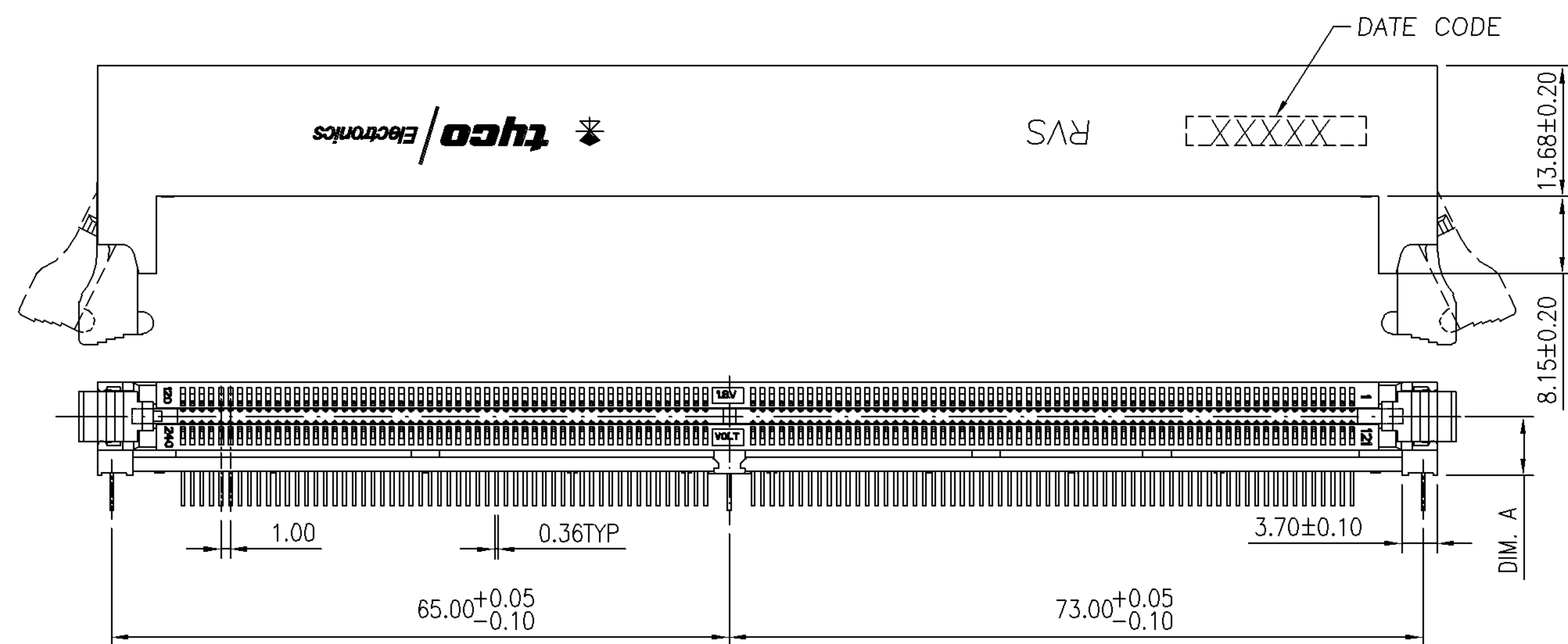

REVERSE TYPE

DIM. B	DIM. A	MIN. GOLD PLATING	DIM. L	PART NUMBER
12.30	8.70	0.75μm [30μ"]	3.60	5- -8
			3.18	5- -7
			2.54	5- -6
9.80	6.20	0.375μm [15μ"]	3.60	4- -8
			3.18	4- -7
			2.54	4- -6
		0.05μm [2μ"]	2.00	4- -5
			3.60	3- -8
			3.18	3- -7
		0.75μm [30μ"]	2.54	5- -2
			2.00	5- -1
			3.60	4- -4
		0.375μm [15μ"]	3.18	4- -3
			2.54	4- -2
			2.00	4- -1
		0.05μm [2μ"]	3.60	3- -4
			3.18	3- -3
			2.54	3- -2
			2.00	3-1775841-1

TOLERANCES UNLESS OTHERWISE SPECIFIED: 0 PLC ± 1 PLC ±0.3 2 PLC ±0.2 3 PLC ± ANGLES ±3'	DWN S. HOU 17-MAR-2006	tyco Electronics NAME TYCO HOLDINGS (BERMUDA) VII LTD. TAIWAN BRANCH
MATERIAL SEE NOTE	CHK W.J. KE 17-MAR-2006	
FINISH SEE NOTE	APVD W.J. KE 17-MAR-2006	DDR DIMM SOCKET 240P, R/A, DIP CONNECTOR
WEIGHT SEE NOTE	QUALIFICATION TEST REPORT	LOC DW A ₃ SIZE DRAWING NO C-1775841 REV A
		SCALE -- SHEET 3 OF 6

SEE SHEET 1			
LTR	REVISION RECORD	ECN	DWN CHK DATE

NUMBER
C-1775841

3RD ANGLE PROJECTION

METRIC

THIS INFORMATION IS CONFIDENTIAL AND IS DISCLOSED TO YOU ON CONDITION THAT NO FURTHER DISCLOSURE IS MADE BY YOU TO OTHER THAN AMP PERSONNEL WITHOUT WRITTEN AUTHORIZATION FROM AMP (TAIWAN) LTD. DIMENSIONS IN MILLIMETERS. DO NOT SCALE PRINT.

PRINT DIST
DW

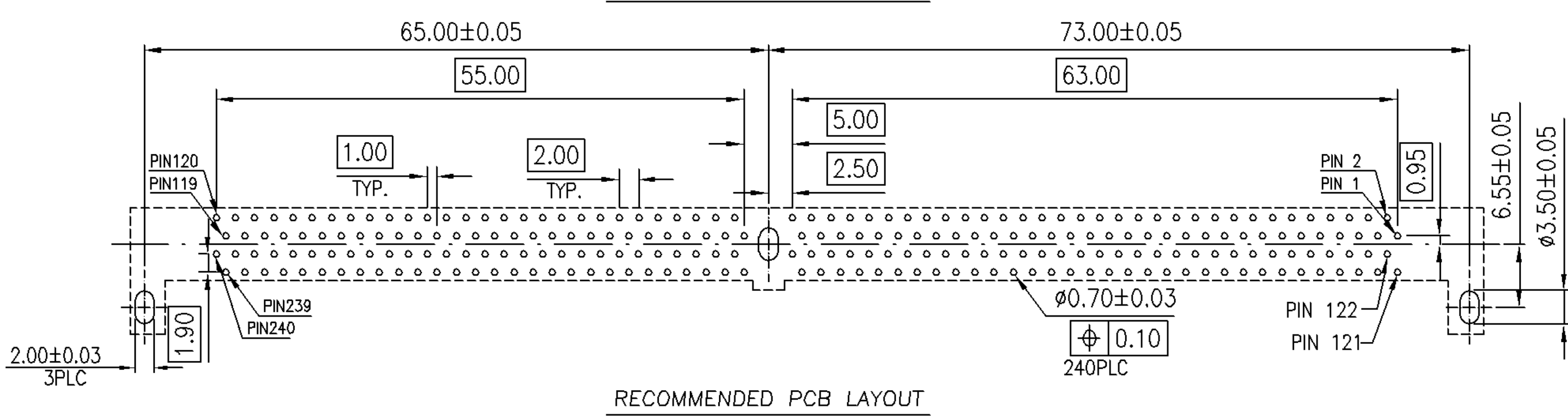
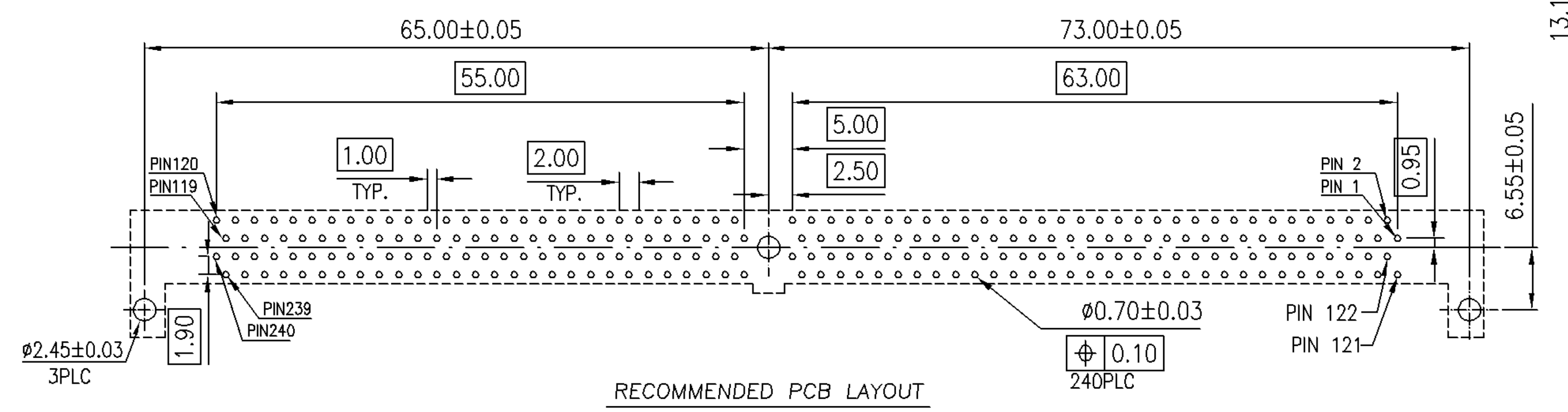
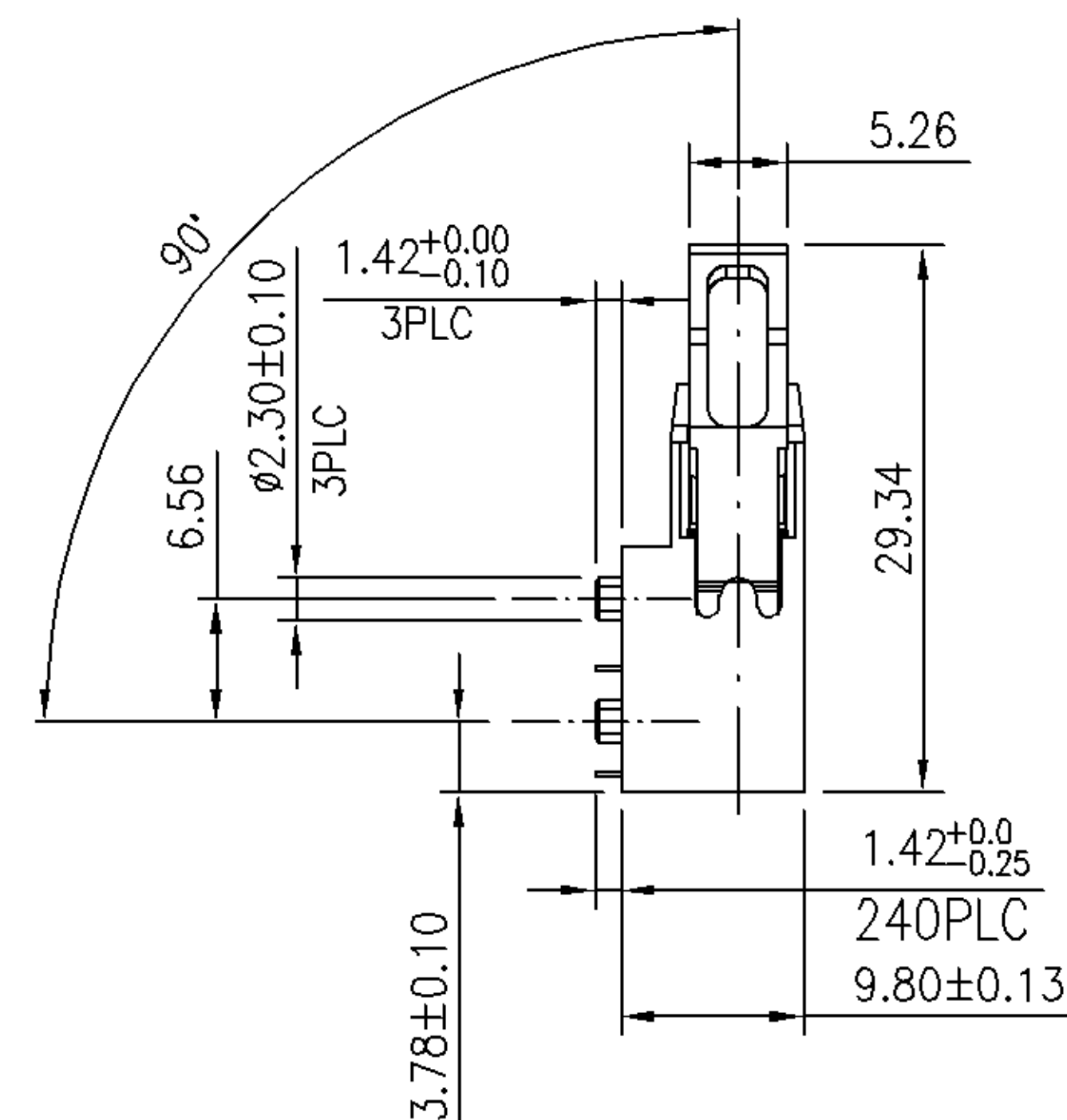
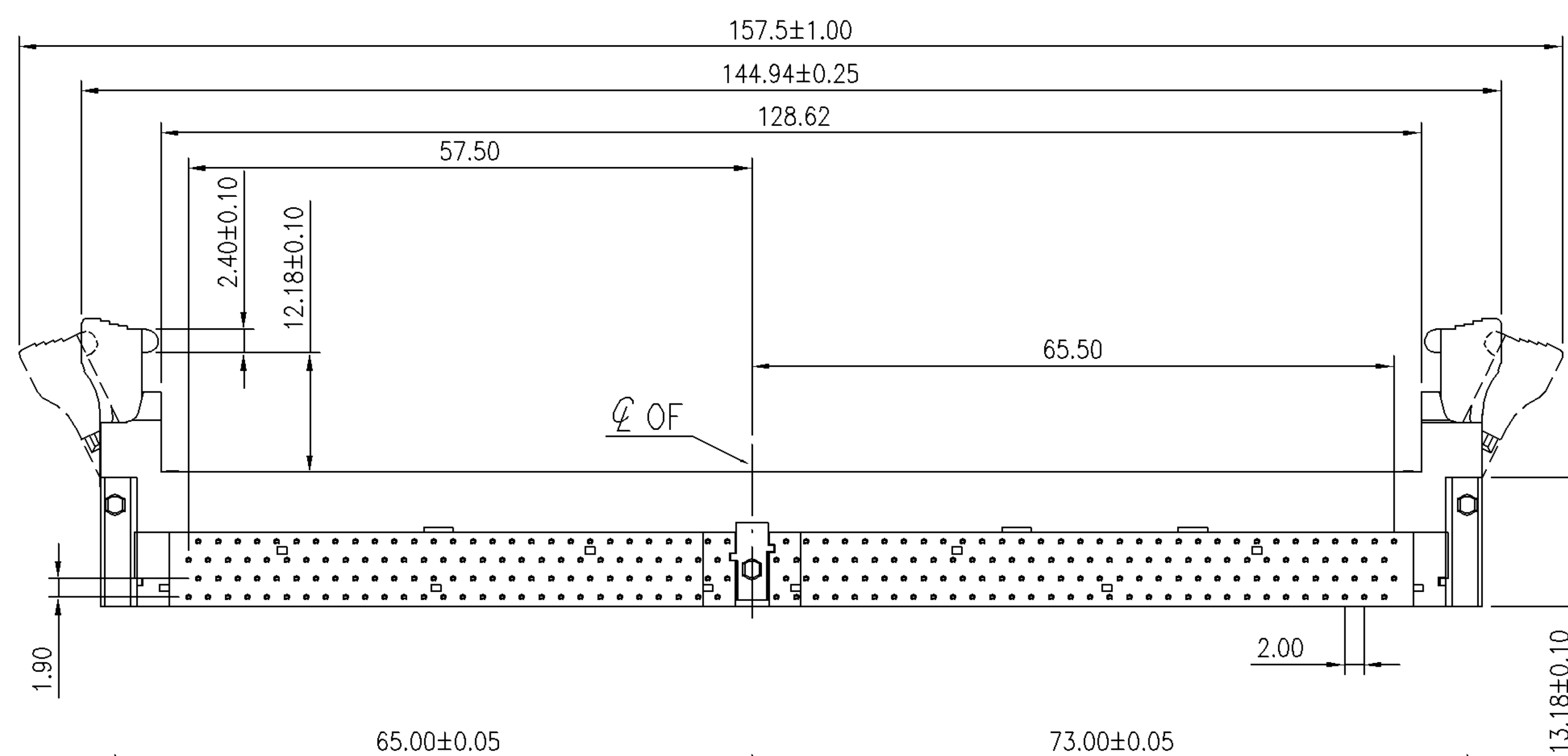
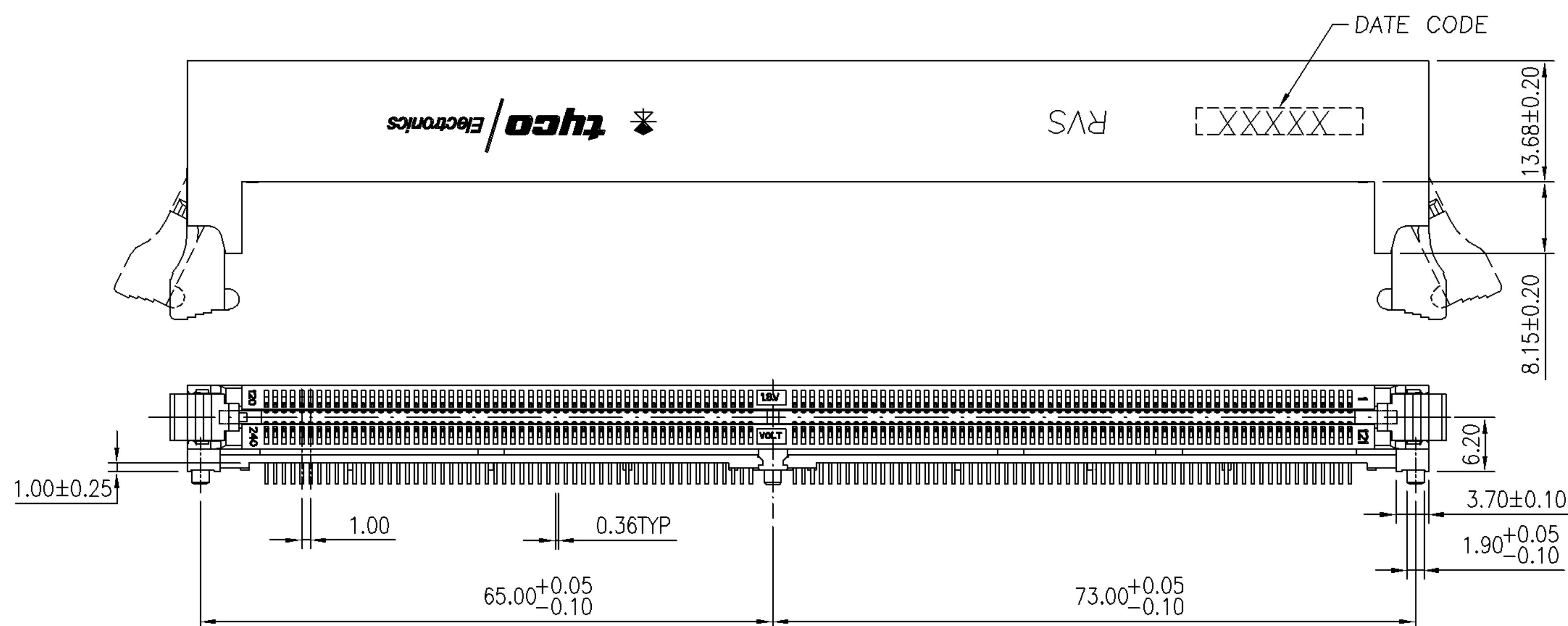

REVERSE TYPE

SEE SHEET 1	ECN	DWN	DATE
LTR	REVISION RECORD	CHK	

TOLERANCES UNLESS OTHERWISE SPECIFIED: 0 PLC ± 1 PLC ±0.3 2 PLC ±0.2 3 PLC ± ANGLES ±3'	DWN S. HOU 17-MAR-2006 CHK W.J. KE 17-MAR-2006
MATERIAL SEE NOTE	APVD W.J. KE 17-MAR-2006
FINISH SEE NOTE	QUALIFICATION TEST REPORT WEIGHT 9.13 GRAM

LOC DW	SIZE A ₃	DRAWING NO C-1775841	REV A
SCALE --		SHEET 4 OF 6	

30μ" MIN. 5-1775841-9		GOLD PLATING		PART NUMBER	
tyco TYCO HOLDINGS (BERMUDA) VII LTD. TAIWAN BRANCH Electronics NAME DDR DIMM SOCKET 240P, R/A, DIP CONNECTOR					

CUSTOMER DRAWING

8 7 6 5 4 3 2 1

D

C

B

A

NUMBER
C-1775841

METRIC
3RD ANGLE PROJECTION

THIS INFORMATION IS CONFIDENTIAL AND IS DISCLOSED TO YOU ON CONDITION THAT NO FURTHER DISCLOSURE IS MADE BY YOU TO OTHER THAN AMP PERSONNEL WITHOUT WRITTEN AUTHORIZATION FROM AMP (TAIWAN) LTD. DIMENSIONS IN MILLIMETERS. DO NOT SCALE PRINT.

PRINT DIST
DW

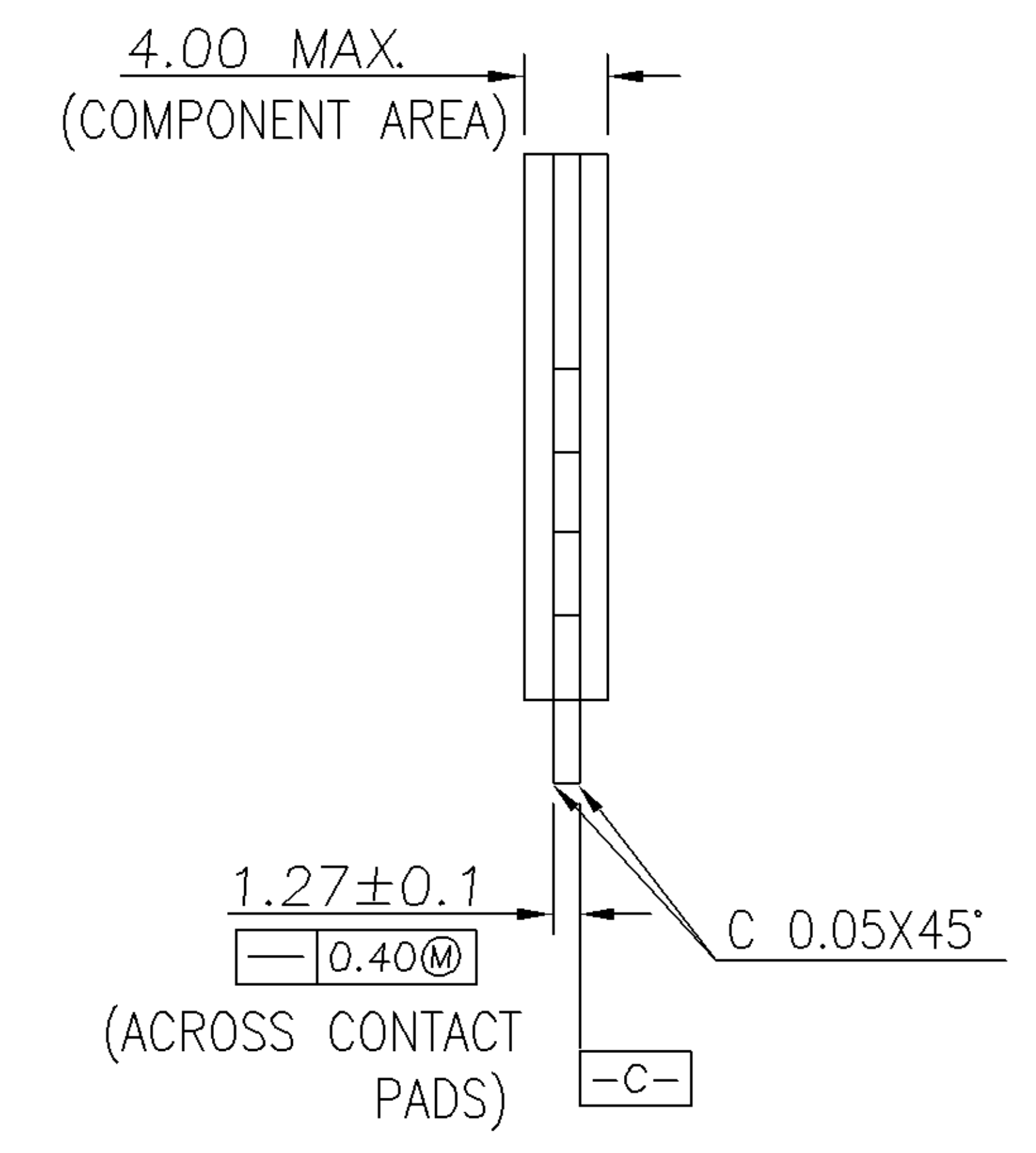
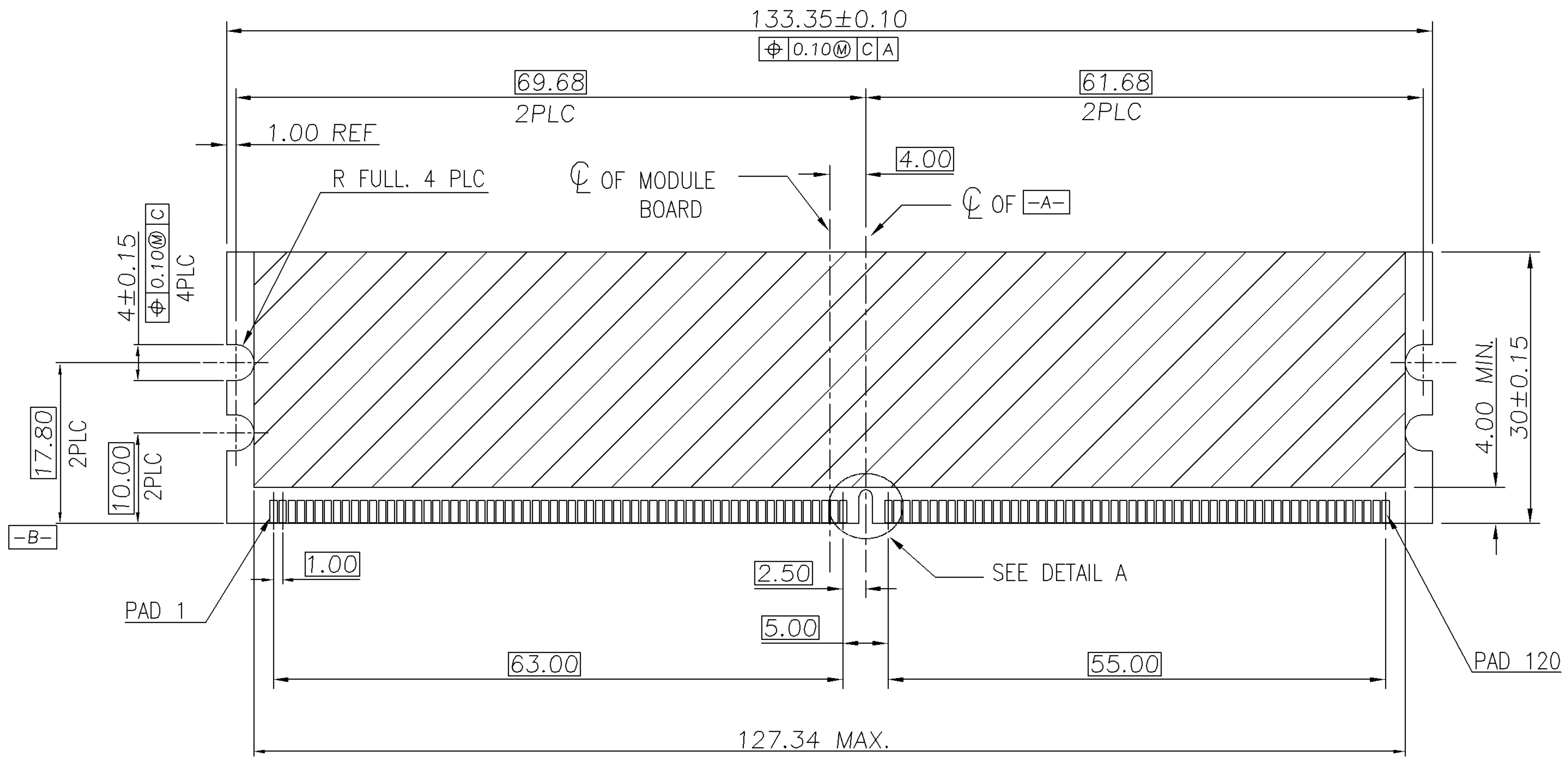

PLUG COMPONENT:DDR II 240P FUNCTION CARD

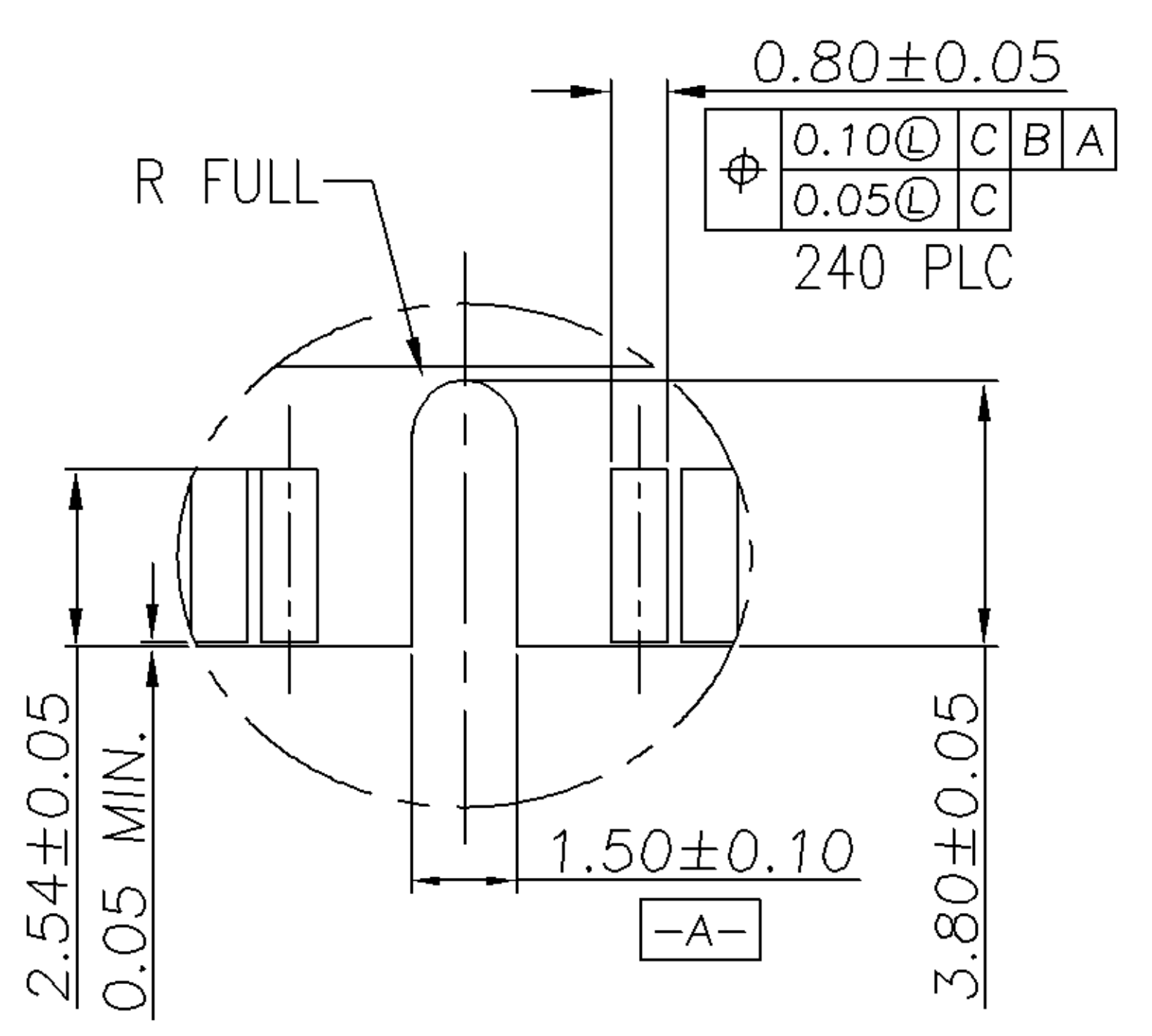

DETAIL A
SCALE 3:1 (1.8V)

SEE SHEET 1	ECN	DWN	DATE
LTR	REVISION RECORD	CHK	

TOLERANCES UNLESS OTHERWISE SPECIFIED: 0 PLC ± 1 PLC ±0.3 2 PLC ±0.2 3 PLC ± ANGLES ±3'	DWN	S. HOU	TYCO HOLDINGS (BERMUDA) VII LTD. TAIWAN BRANCH		
	CHK	W.J. KE			
MATERIAL	APVD	W.J. KE	NAME DDR DIMM SOCKET 240P, R/A, DIP CONNECTOR		
	PRODUCT SPEC	17-MAR-2006			
FINISH	QUALIFICATION TEST REPORT	LOC	SIZE	DRAWING NO	REV
	WEIGHT	DW	A ₃	C-1775841	A
		SCALE		SHEET	
		--		5 OF 6	

8 7 6 5 4 3 2 1
CUSTOMER DRAWING

THIS INFORMATION IS CONFIDENTIAL AND IS DISCLOSED TO YOU ON CONDITION THAT NO FURTHER DISCLOSURE IS MADE BY YOU TO OTHER THAN AMP PERSONNEL WITHOUT WRITTEN AUTHORIZATION FROM AMP (TAIWAN) LTD. DIMENSIONS IN MILLIMETERS. DO NOT SCALE PRINT.

PRINT DIST
DW

METRIC

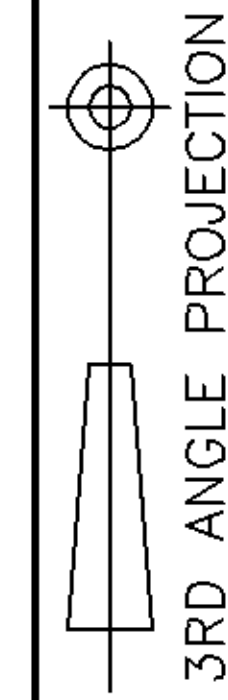

NUMBER
C-1775841

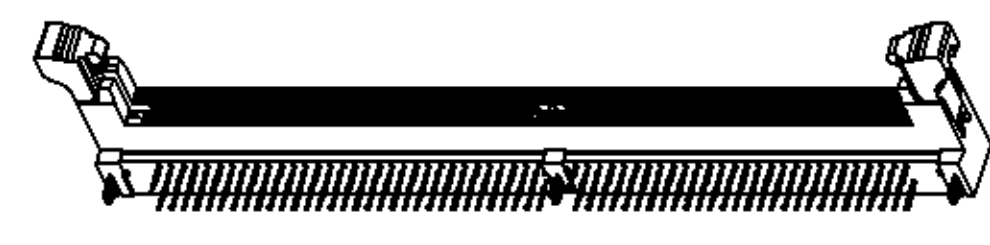
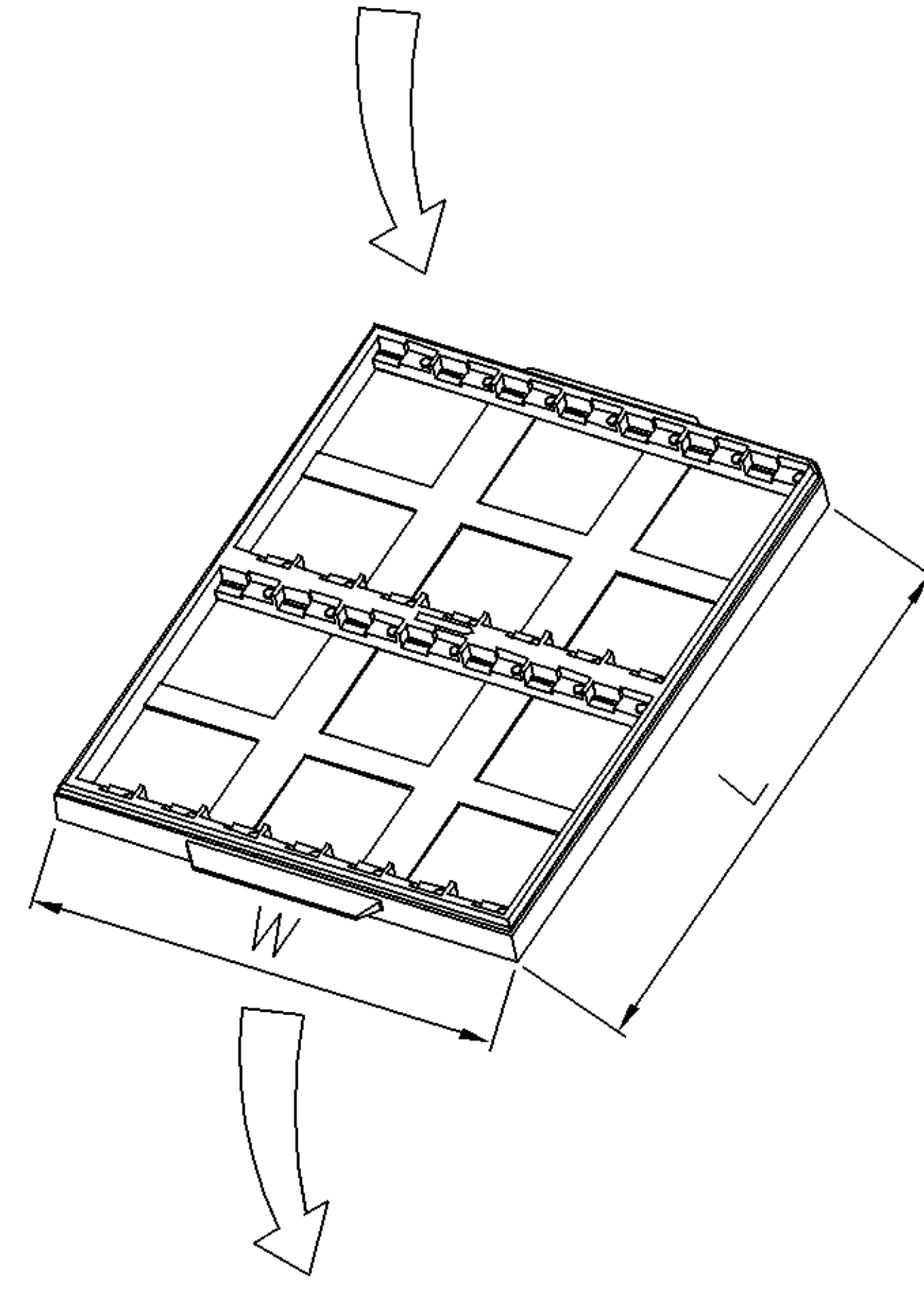
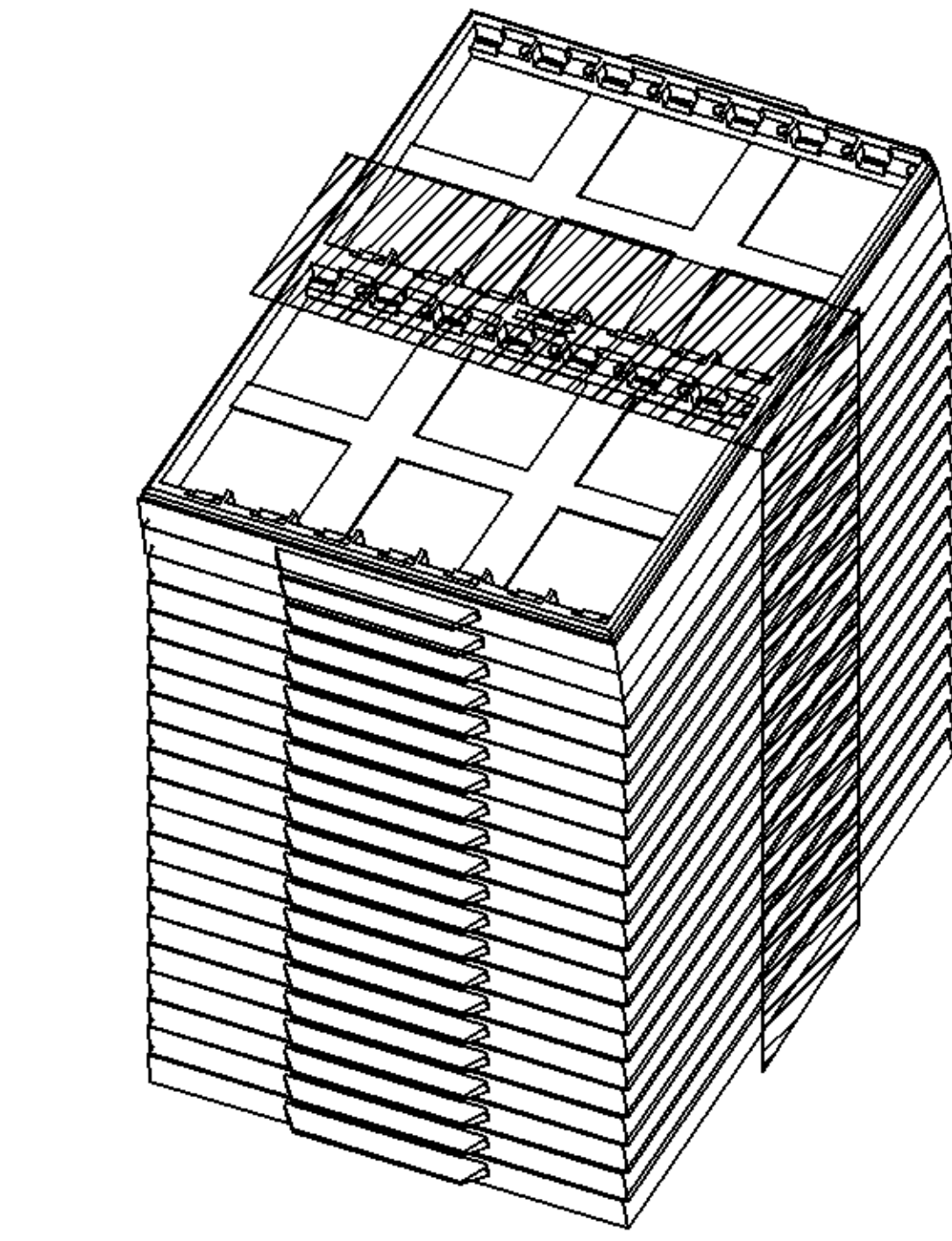
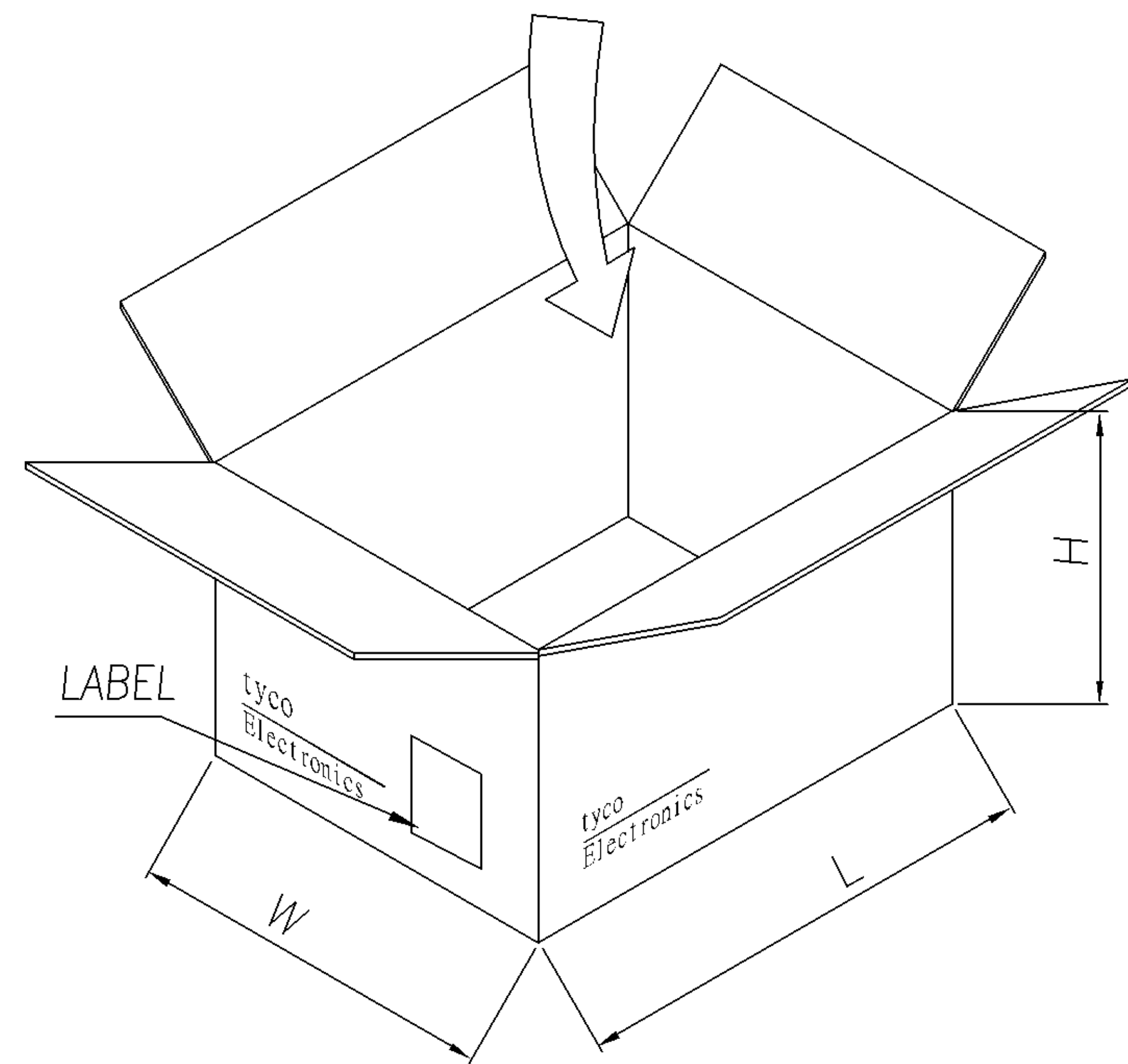

NOTES :

1. MATERIAL :
 - 1.1 TRAY : PS(BLACK)
 - 1.2 SHIPPING CARTON : CORRUGATED FIBERBOARD
2. DIMENSION :
 - 2.1 TRAY : L=335, W=239, H=22
 - 2.1 SHIPPING CARTON : L=365, W=255, H=365
3. QUANTITY :
 - 3.1 PRIMARY PACKING: 14 PCS/TRAY
 - 3.2 SECONDARY PACKING: 21TRAY/CARTON
(THE TOP TRAY IS EMPTY)280PCS/CARTON.
4. WEIGHT :
 - 4.1 NET WEIGHT : 2.56Kg
 - 4.2 GROSS WEIGHT : 5.84Kg

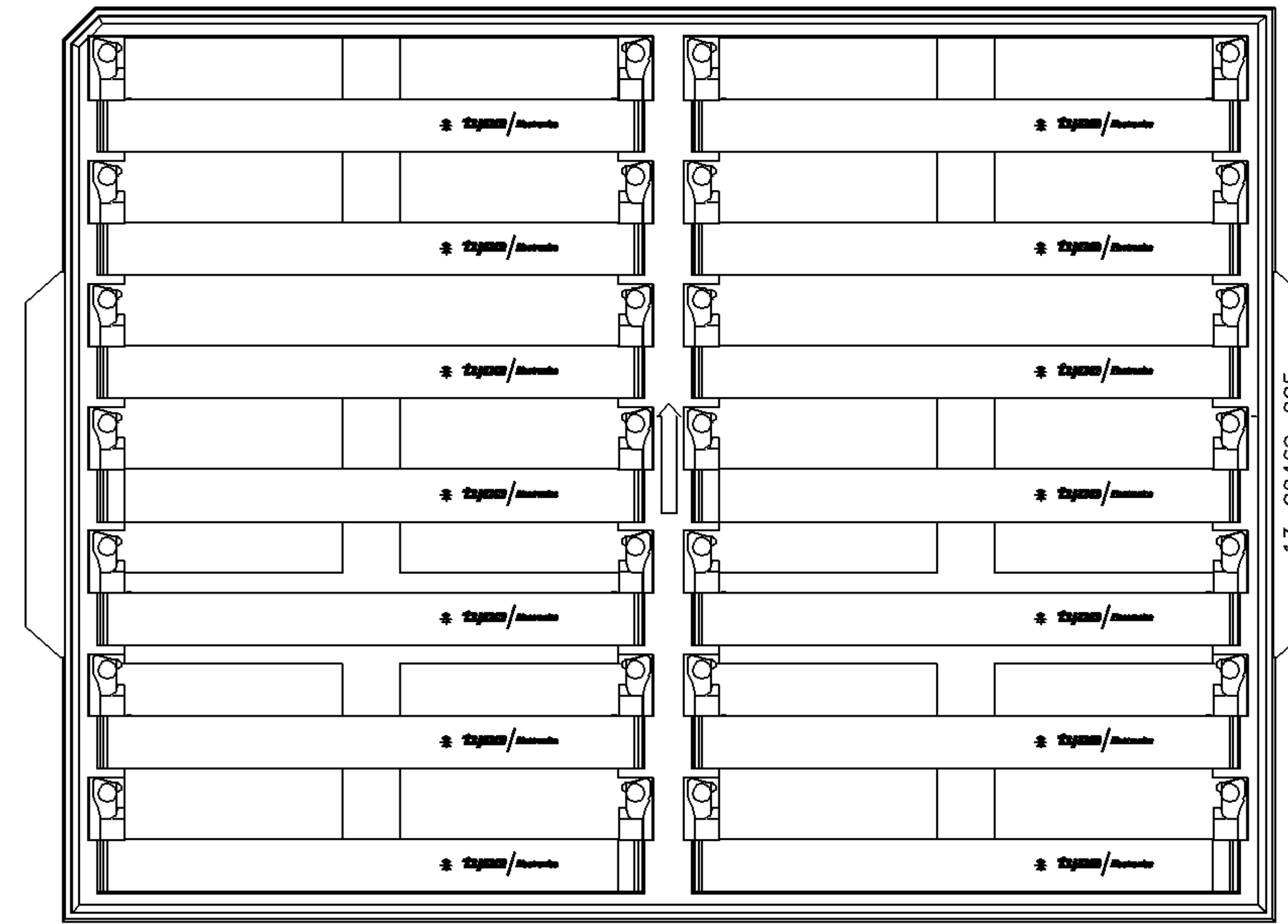

TRAY LAYOUT

SEE SHEET 1			
LTR	REVISION RECORD	ECN	DWN CHK
			DATE

TOLERANCES UNLESS OTHERWISE SPECIFIED: 0 PLC ± 1 PLC ±0.3 2 PLC ±0.2 3 PLC ± ANGLES ±3'	DWN	S. HOU 17-MAR-2006	tyco Electronics	TYCO HOLDINGS (BERMUDA) VII LTD. TAIWAN BRANCH	
	CHK	W.J. KE 17-MAR-2006		NAME	
MATERIAL	APVD	W.J. KE 17-MAR-2006	DDR DIMM SOCKET 240P, R/A, DIP CONNECTOR		
SEE NOTE	PRODUCT SPEC		LOC	SIZE	DRAWING NO
FINISH	QUALIFICATION TEST REPORT		DW	A ₃	C-1775841
SEE NOTE	WEIGHT		SCALE		SHEET
			--		6 OF 6

D
C
B
A